

Product Data Sheet

High Pressure Adsorption Dryer

DHW 50 bar (Generation -04)

Version: 1.8.0

Author: Tassilo Tappe

Date: 13.07.2018

Field of application

Adsorption dryers of the DHW series are designed for drying compressed air and nitrogen to pressure dew points of -20°C to -55°C (depending on the design) at operating pressures of up to 50 bar.

Function

For drying the compressed air, i.e. "adsorption", the compressed air flow is led through a vessel filled with desiccant. The desiccant extracts moisture from the compressed air and stores it in its structure until the desiccant is saturated with moisture. The saturated desiccant then has to be regenerated, i.e. the moisture stored in the structure has to be "removed" before the desiccant can be used for drying again.

Continuous operation of an adsorption dryer therefore requires two vessels that are operated alternately. One vessel is used for drying the compressed air (adsorption) and the other vessel for regenerating the desiccant. For the DHW series the change interval between adsorption and regeneration is 10 minutes at nominal conditions.

For the DHW series a certain quantity of dried compressed air is drawn off at the dryer outlet (*approx. 5 % of the nominal volume flow rate at nominal conditions*). This amount of compressed air is expanded to atmospheric pressure and is led through the vessel to regenerate the desiccant. The dried, decompressed air is extremely moisture-subsaturated and thus extracts the moisture stored in the desiccant and discharges it to the atmosphere via a silencer (heatless regeneration).



Abb. DHW 19/50 with several Options
(2nd pre filter, 2nd after filter, timer controlled condensate drains, differential pressure gauges, start-up device (Pressure maintaining valve) and dew point measurement)

Product Data Sheet

High Pressure Adsorption Dryer DHW 50 bar

Features

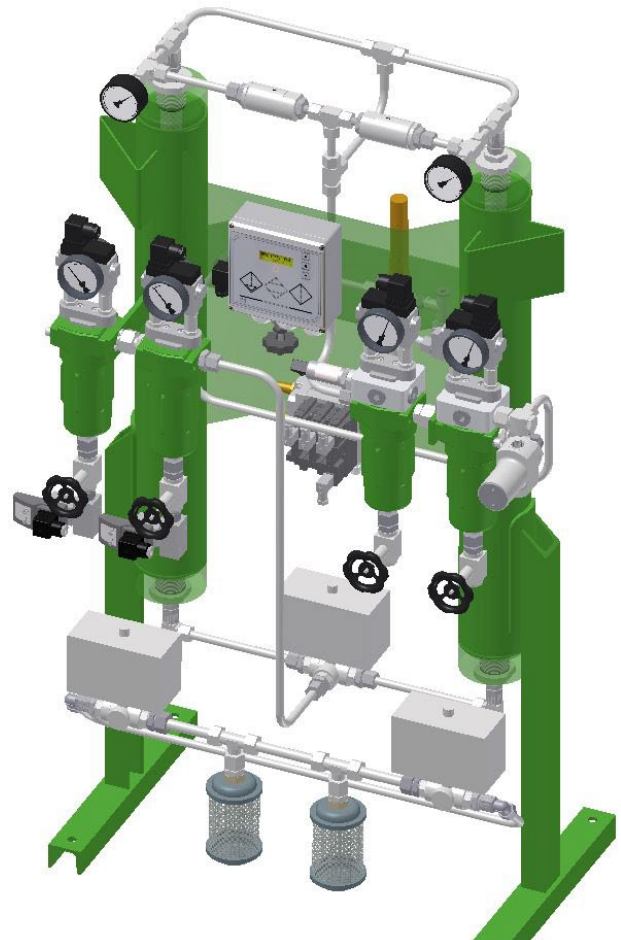
The desiccant has a high drying capacity for moisture and a long service life of several years. This ensures permanently low and stable pressure dew points.

The valves and flow paths required for vessel chamber switch-over are completely installed by high pressure pipes and fittings. The necessary pipe cross sections are calculated individual for each dryer.

The main and regeneration valves are controlled via a solenoid valve block consists of 3 pilot-controlled valves which supply the double acting actuators with control air. To secure the main flow at dryer outlet are 2 non-return valves (with big cross section made by FST) mounted in the upper pipe work. One or several silencer (depends on dryer size) are used for effective reduction of the expansion noise.

The valves of the DHW series are controlled by means of a type "C1" processor control system with a 2-line clear text display and 3 operating keys. The control system is installed in a plastic housing with IP65 protection. The clear text display is used for direct and easy-to-understand indication of the operating state, errors, runtimes, service messages etc. If a pressure dew point sensor (option H) is connected, the current pressure dew point of the compressed air is also directly shown on the display and provided as a 4-20 mA signal. The pressure dew point measurement (option H) allows for dew-point dependent operation of the dryer. Depending on the load of the dryer, the adsorption cycle may be extended, i.e. the switch-over frequency is adapted to the operating situation. This minimise the regeneration air consumption and thus the energy costs are minimised.

In addition, the control system provides a compressor synchronising contact. It is used for synchronous operation of the dryer and a compressor which additionally reduces the regeneration air consumption. This function can also be used in conjunction with dew point-dependent operation.

If a differential pressure monitoring system with alarm contact is fitted to the prefilter and afterfilter (option), the alarm contacts can be connected to the control system, displayed and processed.

As standard, the dryer is provided with a prefilter (fine filter) which prevents solid and liquid contaminants from entering the dryer. This increases the service life of the dryer. An afterfilter (general purpose filter) is also provided as standard. It is used to prevent desiccant dust from entering the downstream system. The filters are already fitted to the dryer by using high pressure steel pipes and fittings. (Pipe work in stainless steel on request)

The dryers comply with the requirements of the Pressure Equipment Directive 2014/68/EU, and have the CE marking of this European directive.



Product Data Sheet

High Pressure Adsorption Dryer DHW 50 bar

Specifications subject to change without notice

Date 13.07.2018

Latest version see www.fstweb.de

Basic data

model	Nominal volume flow* ¹	Min./Max. allowable operating pressure	Min./Max. allowable operating temperature
DHW 11 / 50	45 m ³ /h	10 - 50 bar	+2°C - +60°C
DHW 19 / 50	90 m ³ /h		
DHW 39 / 50	200 m ³ /h		
DHW 49 / 50	245 m ³ /h		
DHW 72 / 50	355 m ³ /h		
DHW 96 / 50	475 m ³ /h		
DHW 156 / 50	825 m ³ /h		
DHW 239 / 50	1255 m ³ /h		

*1 - referred to 1 bar(a) and 20°C at 100 bar operating pressure, inlet temperature 35°C and pressure dew point at outlet -40°C

Purity classes according to ISO 8573-1

Contamination	
Solid particles * ²	(Class 2)
Water content * ²	Class 1-3 * ³
Total oil content * ²	Class 1 * ⁴

*2 - typical result, on the assumption that the suitable inlet concentrations and operating and marginal conditions are given

*3 - depending on the design

*4 - the oil vapour content is not taken into account, it may reduce the purity class

Maintenance rules

	Maintenance interval and maintenance activities
All models	<ul style="list-style-type: none"> ■ Once a week : <ul style="list-style-type: none"> - Check differential pressure on the prefilter and afterfilter (if installed) - Check function of the condensate drain on the prefilter (if installed) ■ Every 12 months : <ul style="list-style-type: none"> - Replace filter elements on pre filter and after filter - Check expansion silencer, clean or replace, if required (SP-FSC-B15F-SV) - Calibrate dew point sensor (option H) (interchange principle possible) ■ Every 24 months : <ul style="list-style-type: none"> - Replace solenoid valve block (Art.-no.: SP-VVB230/3-WVM07-REX) with 230VAC ■ Every 4 years <ul style="list-style-type: none"> - Replace desiccant *⁵*⁶ (Art. no. SEDAFILL-DHW .. /...) - Replace flow distributors (Art.-no. : SP-PWS32-DHW25-500bar)

*5 – The regular service life of the desiccant is 2 - 3 years, however, it is very much depending on the contamination level of the incoming compressed air and the operating temperature. In order to achieve the specified service life of the desiccant, it is vital to exchange the filter elements as described above.

*6 – The desiccant must be disposed of according to the European waste code. A possible oil contamination must be taken into account.

Product specific data

Specification	
Pressure dew points	-25°C / -40°C / -55°C
Electrical connection	230V 50/60 Hz, alternative 115V 50/60Hz or 24V DC
Power consumption	< 50 Watt
Protection Class	IP 65 (Nema 4)
Valve switching power (for each valve)	10 VA

Product Data Sheet

High Pressure Adsorption Dryer DHW 50 bar

Specifications subject to change without notice

Date 13.07.2018

Latest version see www.fstweb.de

Materials

Component	
Vessel and screw taps	carbon steel St.35.8, P265GH (optional Stainless steel)
Frame and supports	carbon steel (optional Stainless steel)
Coating	Outside : sand blasted SA2,5 (ISO8501) ; 1-component primer on alkyd resin base ; dry thickness approx 40 µm (e.g. DuPont PercoTop 021, or similar product) 2-component acrylic resin paint ; dry thickness approx 40 µm (e.g. DuPont PercoTop 9600, or similar product)
Stream distributor	Stainless steel 316
Valve (ball valves)	Stainless steel 1.4408
Sealing materials	NBR, PEEK, Hostaform C/9.4002
Screws	8.8 steel, zinc-plated
Pipe connection dryer internal	tubes and fittings steel, galvanised (optional Stainless steel 316)
Pipe connection to pre- and afterfilter	tubes and fittings steel, galvanised (optional Stainless steel 316)
Desiccant filling	80% Molecular sieve 4A and 20% Silicagel WS as water resistant bottom layer
Mounted pre filter and after filter	See product data sheets for filter housing and filter elements

Connections, dimensions and weight (including pre filter and after filter)

Model	connection	Height	Width incl. pre- & after filter	Depth	Weight
DHW 11 / 50	G 1/2	1080 mm	700 mm	470 mm	80 kg
DHW 19 / 50	G 1/2	1330 mm	700 mm	470 mm	90 kg
DHW 39 / 50	G 1/2	1430 mm	750 mm	500 mm	110 kg
DHW 49 / 50	G 1/2	1640 mm	750 mm	500 mm	130 kg
DHW 72 / 50	G 1/2	1750 mm	930 mm	500 mm	155 kg
DHW 96 / 50	G 1/2	1750 mm	980 mm	525 mm	185 kg
DHW 156 / 50	*)	1770 mm	1080 mm	575 mm	240 kg
DHW 239 / 50	*)	1770 mm	1190 mm	630 mm	360 kg

*) depends on operating conditions (volume flow and pressure), and so from selected filter size : 1/2" or 3/4"

Product Data Sheet

High Pressure Adsorption Dryer DHW 50 bar



Specifications subject to change without notice

Date 13.07.2018

Latest version see www.fstweb.de

Classification according to Pressure Equipment Directive 2014/68/EU for group 2 fluids

Model	Volume	Category	Marking
DHW 11 / 50	2,93 Liter	I	CE 0525
DHW 19 / 50	5,56 Liter	II	CE 0525
DHW 39 / 50	12,09 Liter	II	CE 0525
DHW 49 / 50	14,21 Liter	II	CE 0525
DHW 72 / 50	21,19 Liter	III	CE 0525
DHW 96 / 50	28,13 Liter	III	CE 0525
DHW 156 / 50	49,17 Liter	III	CE 0525
DHW 239 / 50	71,73 Liter	IV	CE 0525

Other Directives

Model	
All models	<p>EMC-Standard (inspection scope for control system, solenoid valves and dew point measurement): <i>Emitted interference acc. :</i> EN 55011:1998 + A1:1999 + A2:2002 (limit value class: B) EN 61000-3-2:2006-04, EN61000-3-3:2008 <i>Interference resistance acc. :</i> EN 61000-6-2:2005</p> <p>Machinery Directive 2006/42/EC is not applicable.</p>

Product Data Sheet

High Pressure Adsorption Dryer DHW 50 bar

Specifications subject to change without notice

Date 13.07.2018

Latest version see www.fstweb.de

Flow diagram (PID)

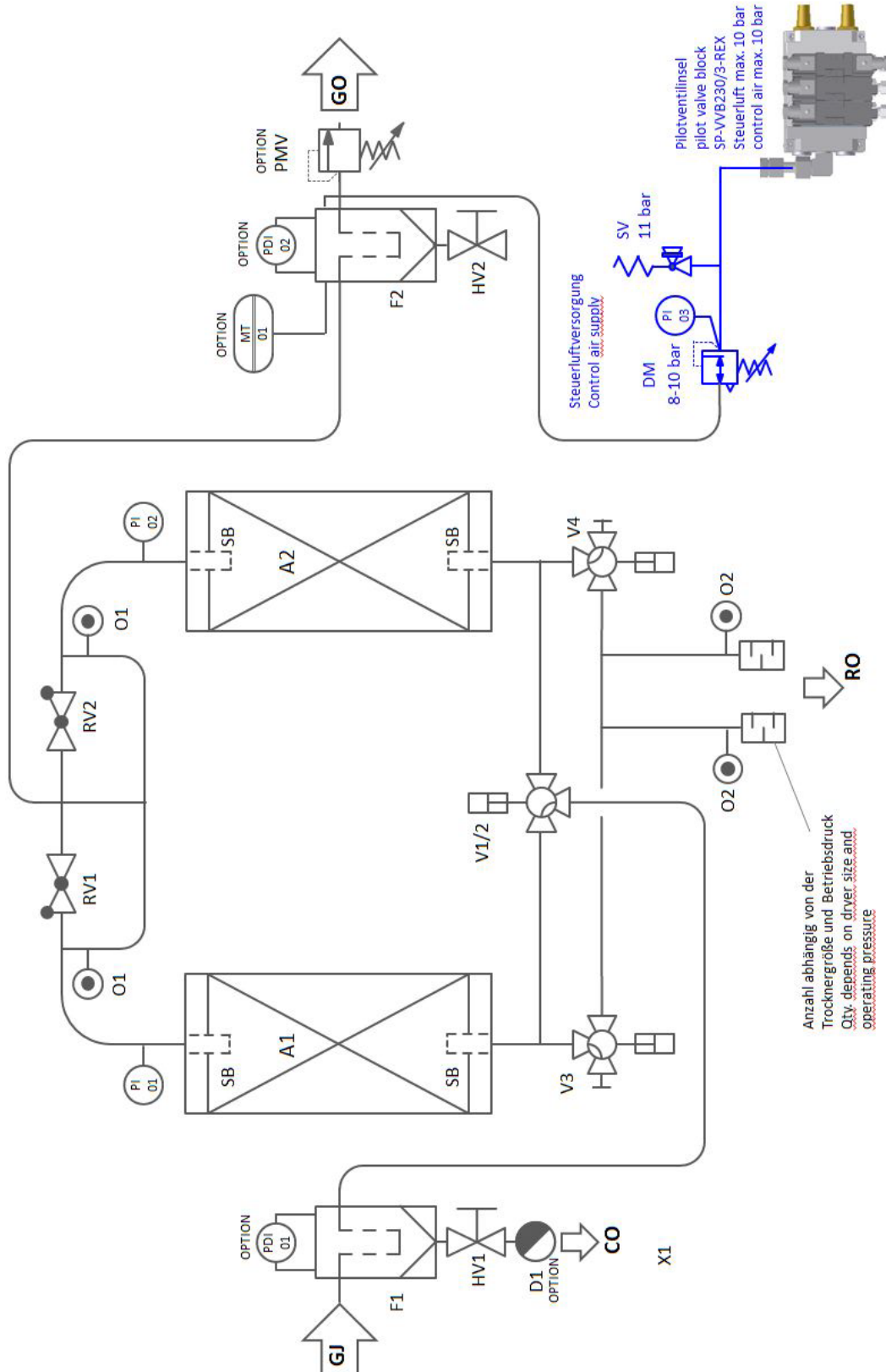

Product Data Sheet

High Pressure Adsorption Dryer DHW 50 bar



Specifications subject to change without notice

Date 13.07.2018

Latest version see www.fstweb.de

Notes

Product Data Sheet

High Pressure Adsorption Dryer DHW 50 bar

Accessories



The DA-CM1-230 switch-over control system enables the control of two redundant compressed air dryers in a compressed air system. The two dryers can be operated alternately while switching-over automatically. All dryers, provided with a «remote start/stop contact» or a «compressor synchronisation contact», can be directly connected to the switch-over control system without the need for any further modifications. The DA-CM1-230 also controls all required shut-off valves (no scope of supply) to open or close the compressed air line to a dryer (e.g. solenoid valves or valves with actuating drive for 230V AC supply voltage). Furthermore, additional input signals can be hooked up to the common alarm message of each dryer. Beside the power supply the DA-CM1-230 provides alarm inputs for condensate drains, differential pressure gauges, etc. for each dryer.

The GSM Module DA-ETR-107 is an easy to install extension for all dryers with alarm contact. In case of an alarm a SMS message is send to up to 6 different recipients or, if supported by the provider, an email message. Within the message, the dryer type and serial number is transferred, if required.

The programming can be done with a usual mobile phone, protected by the PIN code of the SIM card (no scope of supply) applied to the GSM module. The DA-ETR-107 is operated with 5-32V DC supply voltage. An internal battery ensures operation of up to 120 hours in case of loss of the supply voltage. The GSM module has an integrated antenna while an external antenna can be connected in the case of low signal levels.



The Start-up device (minimum pressure valve) DA-VPM-... protects the dryer from overload due to high flow velocities during pressure build-up of the compressed air system. For connection size G ½ to G 2½ spring loaded angle valves are offered (DA-VPM-B../16), providing an opening pressure of 3-5 bar (standard 3.5 bar). For connection size DN80 to DN250 butterfly valves with pneumatic actuator are offered (DA-VPM-F../11), directly operated by the working pressure while opening at 3 bar (full cross-section at 4 bar). Special versions with adjustable opening pressure or working pressures of up to 450 bar are available on request.



Differential pressure gauges FAD01C with potential free alarm contact allow to hook up the differential pressure control of the pre- and after-filter to the common alarm message of each dryer. In order to avoid a false error report due to start-up conditions or short-time peaks, an alarm delay can be set in the dryer control unit. The alarm message then will just be generated, if a too high differential pressure was indicated during the entire delay time interval.

... and many more. Please contact us.